

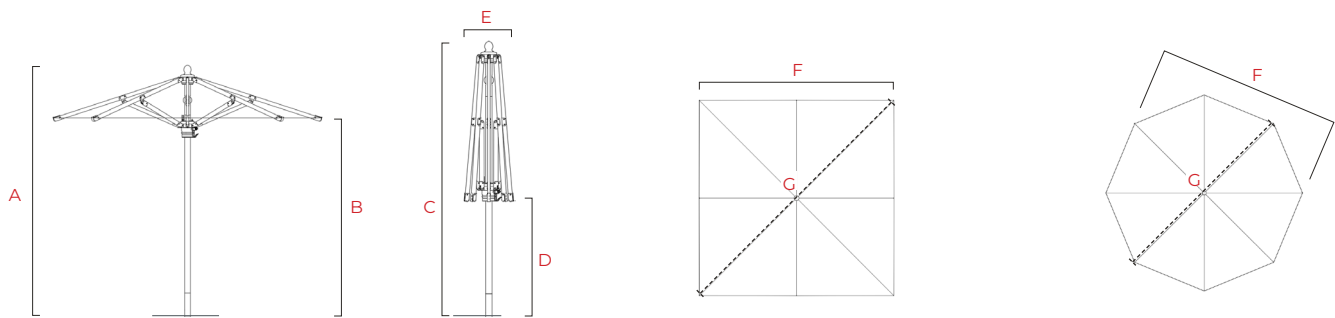

PRODUCT SPECIFICATIONS

OCEAN MASTER MAX NAUTICAL TEAK

LIFT SYSTEM: AUTO-LOC MARINE PULLEY LIFT



SHAPES		SQUARE		OCTAGON	
SIZES (ft/cm)		6.5 / 200	8.0 / 245	9.0 / 275	11.0 / 340
A (in/cm)	MAST HEIGHT (open)	105 / 267	105 / 267	105 / 267	105 / 267
B (in/cm)	CANOPY CLEARANCE	83 / 211	83 / 211	83 / 211	79 / 201
C (in/cm)	MAST HEIGHT (closed)	105 / 267	105 / 267	105 / 267	105 / 267
D (in/cm)	TABLE CLEARANCE	45 / 114	35 / 89	45 / 114	32 / 81
E (in/cm)	PARASOL WIDTH (closed)	13 / 33	19 / 48	18 / 46	20 / 51
F (in/cm)	FLAT TO FLAT	79 / 201	98 / 249	100 / 254	125 / 318
G (in/cm)	POINT TO POINT	111 / 282	138 / 351	108 / 274	135 / 343
(ft ² /m ²)	CANOPY AREA COVERAGE	43 / 4	67.8 / 6.3	58.1 / 5.4	90.4 / 8.4

Dimension Tolerances ± 2" / 5cm. Dimensions shown are rounded to the nearest inch/cm and correspond to indicated lift system. Please check our 2D CAD-files for exact dimensions. Options are subject to change without notice.



PRODUCT SPECIFICATIONS

OCEAN MASTER MAX NAUTICAL TEAK

LIFT SYSTEM: EASYDRIVE CRANK

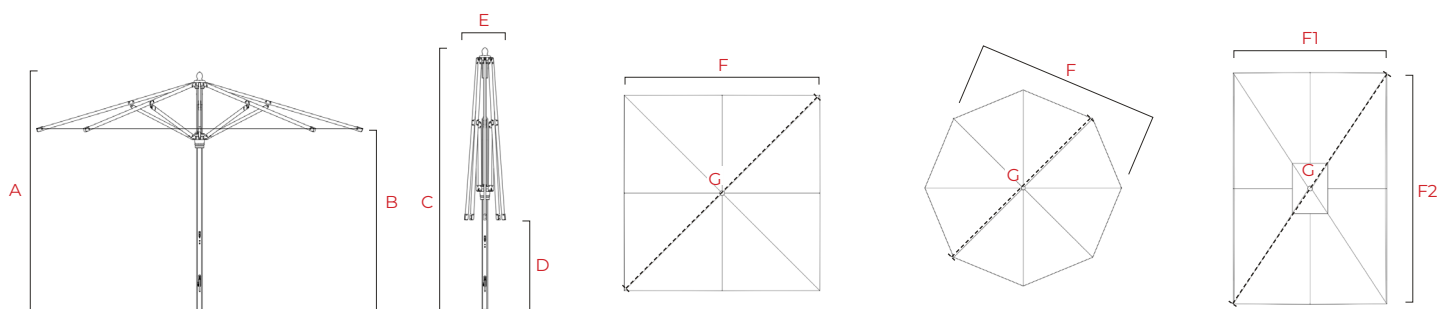

SHAPES		SQUARE	OCTAGON	RECTANGLE
SIZES (ft/cm)		10.0 / 305	13.0 / 400	8.0 x 12.0 / 245 x 365
A (in/cm)	MAST HEIGHT (open)	115 / 292	115 / 292	115 / 292
B (in/cm)	CANOPY CLEARANCE	90 / 229	88 / 224	89 / 226
C (in/cm)	MAST HEIGHT (closed)	134 / 340	136 / 345	133 / 338
D (in/cm)	TABLE CLEARANCE	45 / 114	47 / 119	44 / 112
E (in/cm)	PARASOL WIDTH (closed)	16 / 41	21 / 53	13 / 33
F (in/cm)	FLAT TO FLAT	119 / 302	156 / 396	F1 x F2: 96 x 138 / 244 x 351
G (in/cm)	POINT TO POINT	169 / 429	169 / 429	169 / 429
	(ft ² /m ²) CANOPY AREA COVERAGE	96.9 / 9	139.9 / 13	92.6 / 8.6